



Selector Switches

Style					Knob Type						
											
No. of Positions	Contact Configuration	Contact Block Mounting Position		Operator Position			Maintained	Spring Return from Right	—	—	
		1	2	L	R	—					
90° 2-Position 	1NO (10)	1	NO		●		YW1S-2E10	YW1S-21E10	—	—	
		2									
		3									
	1NC (01)	1						YW1S-2E01	YW1S-21E01	—	—
		2									
		3	NC	●							
	2NO (20)	1	NO		●		YW1S-2E20	YW1S-21E20	—	—	—
		2									
		3	NO		●						
	2NC (02)	1	NC	●			YW1S-2E02	YW1S-21E02	—	—	—
		2									
		3	NC	●							
	1NO-1NC (11)	1	NO		●		YW1S-2E11	YW1S-21E11	—	—	—
		2									
		3	NC	●							
	3NO (30)	1	NO		●		YW1S-2E30	YW1S-21E30	—	—	—
		2	NO		●						
		3	NO		●						
3NC (03)	1	NC	●			YW1S-2E03	YW1S-21E03	—	—	—	
	2	NC	●								
	3	NC	●								
2NO-1NC (21)	1	NO		●		YW1S-2E21	YW1S-21E21	—	—	—	
	2	NO		●							
	3	NC	●								
1NO-2NC (12)	1	NO		●		YW1S-2E12	YW1S-21E12	—	—	—	
	2	NC	●								
	3	NC	●								
No. of Positions	Contact Configuration	Contact Block Mounting Position		Operator Position			Maintained	Spring Return from Right	Spring Return from Left	Spring Return Two-Way	
		1	2	L	C	R					
45° 3-Position 	2NO (20)	1	NO	●			YW1S-3E20	YW1S-31E20	YW1S-32E20	YW1S-33E20	
		2									
		3	NO			●					
	2NO (20N1)	1	NO	●		●	YW1S-3E20N1	YW1S-31E20N1	YW1S-32E20N1	YW1S-33E20N1	
		2	NO	●		●					
		3	NO			●					
	2NC (02)	1	NC		●		YW1S-3E02	YW1S-31E02	YW1S-32E02	YW1S-33E02	
		2									
		3	NC		●						
	2NC (02N1)	1	NO	●			YW1S-3E02N1	YW1S-31E02N1	YW1S-32E02N1	YW1S-33E02N1	
		2	NC		●						
		3	NC		●						
	1NO-1NC (11)	1	NO	●			YW1S-3E11	YW1S-31E11	YW1S-32E11	YW1S-33E11	
		2									
		3	NC		●						
	1NO-1NC (11N1)	1	NC		●		YW1S-3E11N1	YW1S-31E11N1	YW1S-32E11N1	YW1S-33E11N1	
		2									
		3	NO			●					
	1NO-1NC (11N2)	1	NO	●			YW1S-3E11N2	YW1S-31E11N2	YW1S-32E11N2	YW1S-33E11N2	
		2	NC		●						
		3									
	1NO-1NC (11N3)	1					YW1S-3E11N3	YW1S-31E11N3	YW1S-32E11N3	YW1S-33E11N3	
		2	NC		●						
		3	NO			●					
1NO-1NC (11N4)	1	NO	●			YW1S-3E11N4	YW1S-31E11N4	YW1S-32E11N4	YW1S-33E11N4		
	2	NC		●							
	3	NC		●							
3NO (30)	1	NO	●			YW1S-3E30	YW1S-31E30	YW1S-32E30	YW1S-33E30		
	2	NO	●								
	3	NO		●							
3NC (03)	1	NC		●		YW1S-3E03	YW1S-31E03	YW1S-32E03	YW1S-33E03		
	2	NC		●							
	3	NC		●							
2NO-1NC (21)	1	NO	●			YW1S-3E21	YW1S-31E21	YW1S-32E21	YW1S-33E21		
	2	NC		●							
	3	NO			●						
1NO-2NC (12)	1	NC		●		YW1S-3E12	YW1S-31E12	YW1S-32E12	YW1S-33E12		
	2	NO	●								
	3	NC		●							

Contact Block Mounting Position

Contact Block Mounting Position

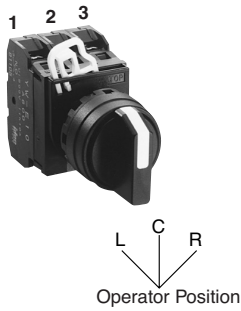



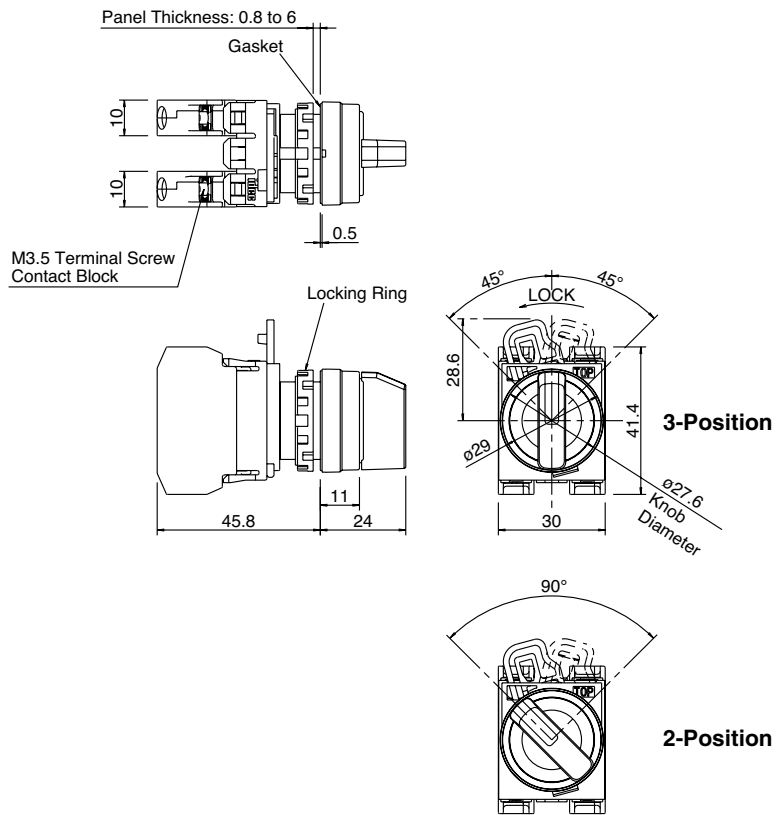





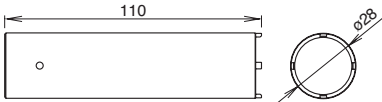

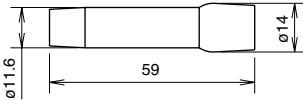

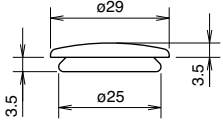
Dimensions (Selector Switch)

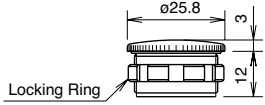

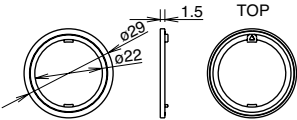
All dimensions in mm.

Accessories

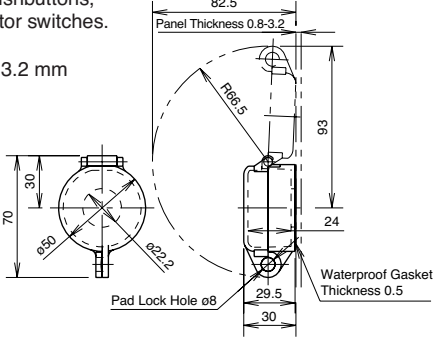
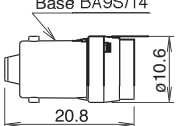
Name & Shape	Type No.	Description & Dimensions (mm)	Package Quantity
	MW9Z-T1	Metallic tool used to tighten the plastic locking ring when installing the YW series control unit on a panel. 	1
	OR-55	Made of rubber. Used for replacing lamps. 	1
	OB-31PN05	Used for plugging unused mounting holes in the panel. Color: Black 	5
	LW9Z-BM	Used for plugging unused mounting holes in the panel. Weight: Approx. 18g 	1
	HW9Z-RLPN10	Prevents rotation of switches in panel. Mainly used with selector switches when no nameplate is used. With waterproof gasket (IP65). Made of plastic (black). Applicable panel thickness: 1.2 to 4.5 mm 	10

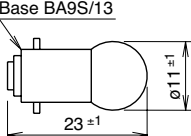
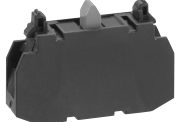
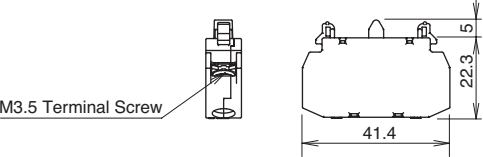
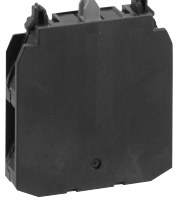
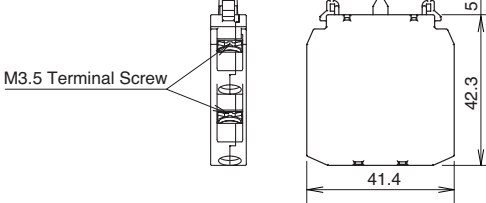
Name & Shape	Type No.	Description & Dimensions (mm)		Package Quantity
	HW9Z-KL1	Plastic hinged cover to protect pushbuttons, illuminated pushbuttons, or selector switches. Degree of protection: IP65. Applicable panel thickness: 0.8 to 3.2 mm 		1
LED Lamp 	LSED-6②	6V AC/DC	Specify a color code in place of ② in the Type No. A (amber), G (green), PW (pure white), R (red), S (blue), Y (yellow) Applicable units: • LED illuminated pilot lights • LED illuminated pushbuttons For the rated current, see page 4. Note: Yellow LED lamps are used for white illumination of pilot lights and illuminated pushbuttons.	1
	LSED-1②	12V AC/DC		
	LSED-2②	24V AC/DC		
LED Lamp 	LSED-H②	110V AC/DC		
Incandescent Lamp 	LS-T6P	6.3V, 1W	One pack contains 100 incandescent lamps.	100
	LS-T8P	18V, 1W		
	LS-T3P	30V, 1W		
Single Contact Block 	YW-E10P	Contact: 1NO		10
	YW-E01P	Contact: 1NC		
Double Contact Block 	YW-EW20P	Contact: 2NO		10
	YW-EW11P	Contact: 1NO-1NC		
	YW-EW01P	Contact: 2NC		